



EXPRESS
MODEL B

QUBICA AMF



EXPRESS MODEL B

SIMPLE TO USE. CLEANS QUICKLY. OILS CONSISTENTLY. SCORES HIGHER.
COSTS HALF THE PRICE.

Why Express Model B?

Specifically Designed To Create A Better Bowling Environment

The Express Model B Lane Machine is simple to use, designed specifically for smaller centers and it's extremely affordable.

In fact, half the price of other machines. Truth is, you just don't need all the bells and whistles those other machines tack on.

And you certainly don't need the added expense. All you really need is a machine that cleans, oils and buffs consistently in a single pass or optional second pass program.

The Express Model B is a great inexpensive back-up machine for larger centers.

With new and improved programming, you can now run a second pass to optimize the lane condition for the highest scores possible within USBC/WTBA rules.

If you're currently using a wickless machine, the Express Model B can be used in "oil only" short run mode. Following a wickless machine, you can apply extra oil in the head area to compensate for some wickless machine's 80 unit limitations.

Specifications

Electrical:

294-115-600 110v 50/60Hz

294-115-620 220v 50/60Hz

Weight:

243 lbs or 110 kg

Machine Dimensions (on approach):

H: 13.93 in /35.38 cm

L: 35.6 in/90.42 cm

W: 55.48 in /140.92 cm

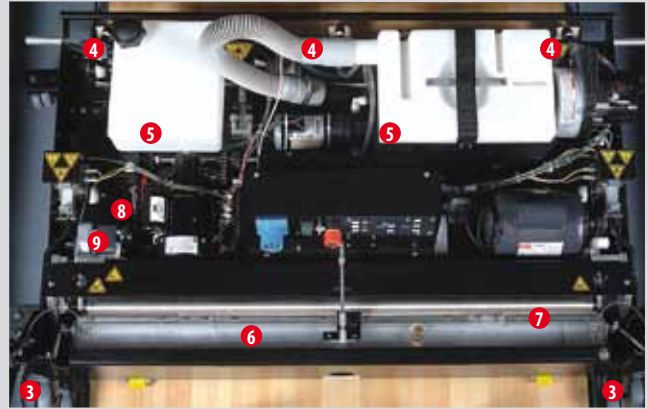

1. Sleek stylish thermo formed hood. (see cover)
2. Improved base plate reduces flexing, resulting in fewer adjustments. (not shown)
3. Larger transport casters make it easier to maneuver.
4. Improved cleaning system features newly designed agitator foam, adjustable spray jets, new control volume valve for fewer drips and dryer gutters.
5. Designed to give you access to cleaner and waste tanks right on top - no hood to open.
6. New oil tanks offers increased oil application with easier adjustments.
7. Optimized default settings and wick adjusting bar provide the ideal oil pattern for higher scores.
8. New counter wheel for accurate distance counting.
9. Transfer roller motor with new internal brake for consistent lengthwise taper of oil pattern resulting in higher scores and less carry down.

QUBICAAMF

WORLDWIDE HEADQUARTERS

8100 AMF Drive - Mechanicsville, VA 23111 - USA - Tel. (804) 569-1000 - Fax: (804) 559-8650 - Toll free 1-866-460-QAMF (7263)

EUROPEAN HEADQUARTERS

Via della Croce Coperta, 15 - 40128 Bologna - Italy - Tel.+39 051.4192.611 - Fax +39 051.4192.602

www.qubicaamf.com - info@qubicaamf.com

